

Assembly Sketch

B205B Antenna
Aluminium

G-Tech Communication Services Pty. Ltd. Trading as :
ZCG SCALAR[®]
DESIGNERS AND MANUFACTURERS OF RADIO FREQUENCY ANTENNAS
Hall Street, Lindenow, Victoria, Australia.
Tel: (03) 5157 1203 Fax: (03) 5157 1641

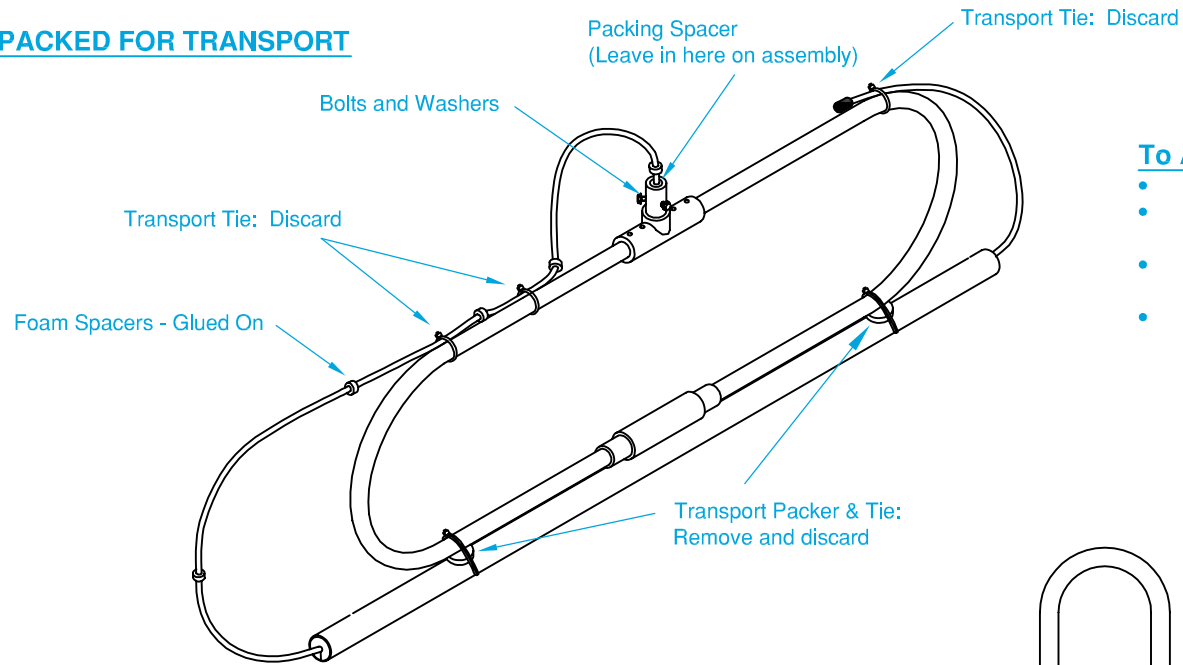

PACKED FOR TRANSPORT**To Assemble Antenna:**

- Remove and discard packing as shown above.
- Hold Connector and carefully pull Cable through Mounting Tube, fitting each Spacer on Cable into Tube.
- Push Mounting Tube fully home into in Dipole Frame Tee-piece and bolt home tight
- For vertical mounting, make sure Drain Hole is downwards.

PARTS SUPPLIED:

Dipole Assembly	1
Flat Washer, Stainless Steel, M5	3
Hex. Head Bolt, Stainless Steel, M5 x 12mm	3
Description	Qty.

NOTES:

- Antenna Mounting Tube dis-assembled and strapped to Dipole frame
- Bolts and Washers are screwed into Mounting Arm

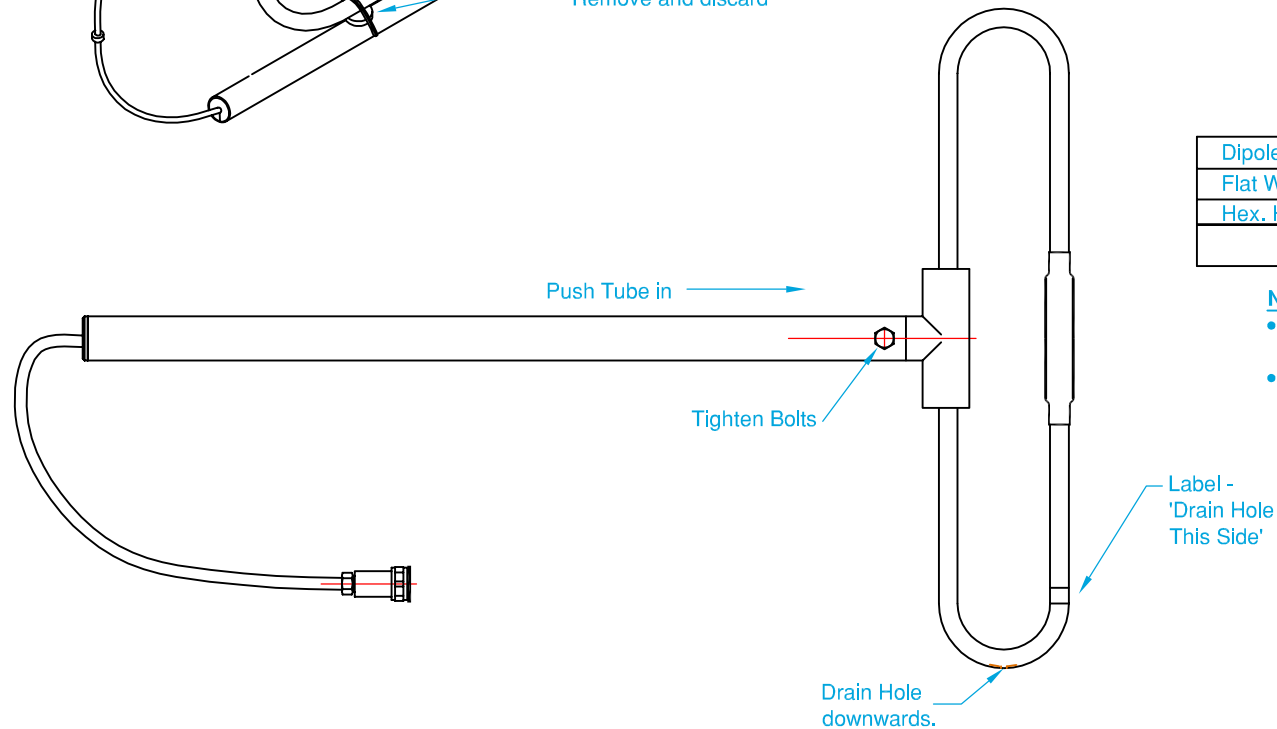
**Assembly Method****B205B Antenna**