

NB:
Antenna to be secured using Clamp Plates at bottom & top of Boom

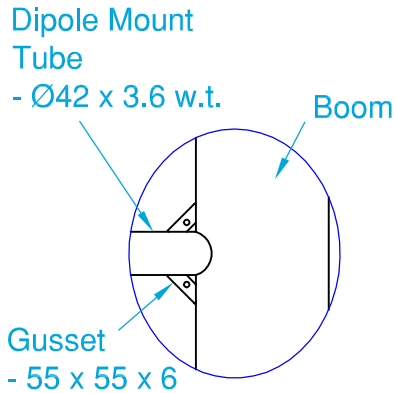

Detail 2:

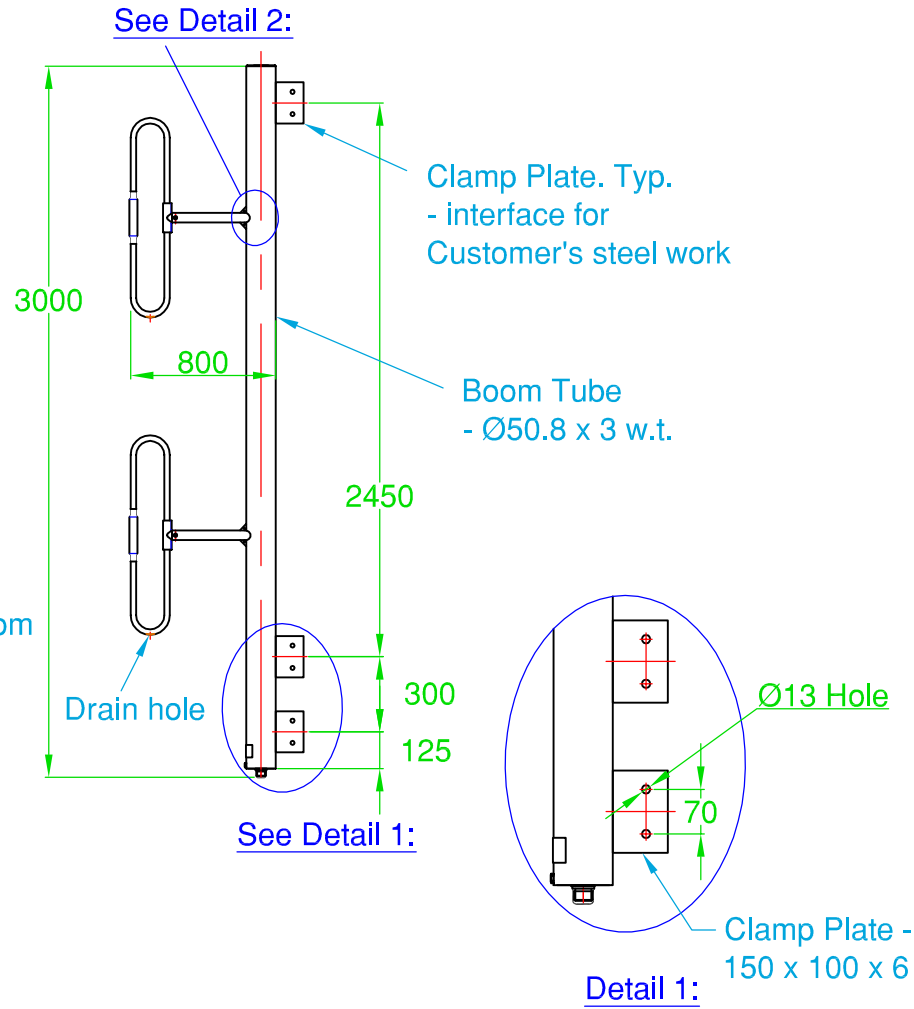
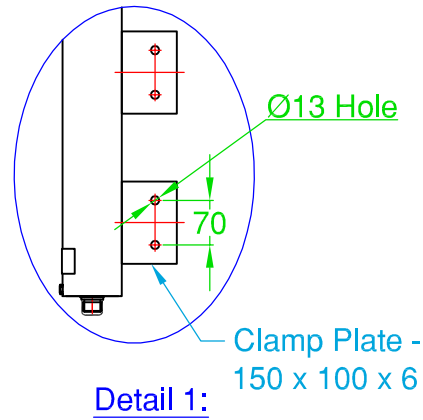

Detail 1:

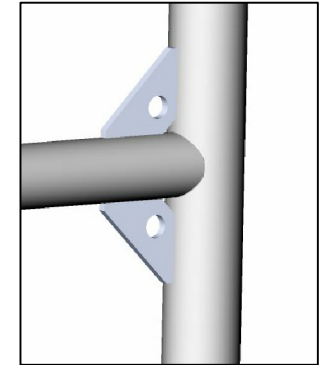
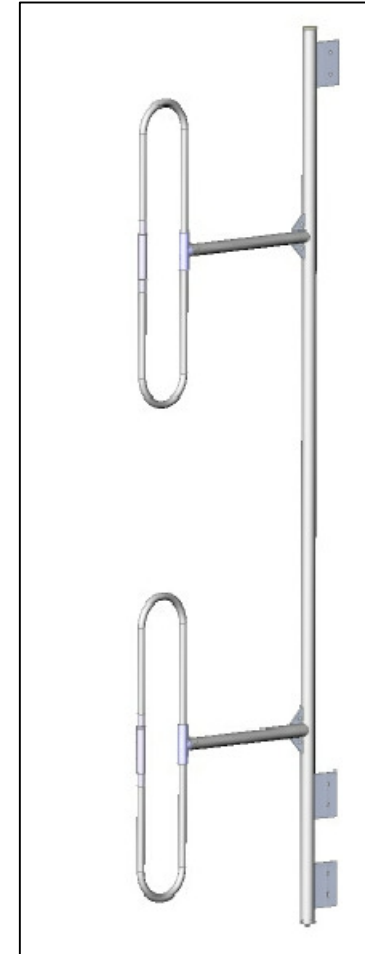

Close-up image of Gusset

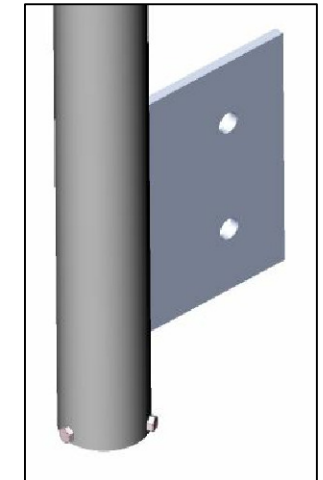

Close-up image of Clamp Plate

Assembly Sketch

S2B42-1CSS-R Stack Array
Ruggedised
(Stainless Steel)